

**CHICAGO**

BULLETIN IAF-103

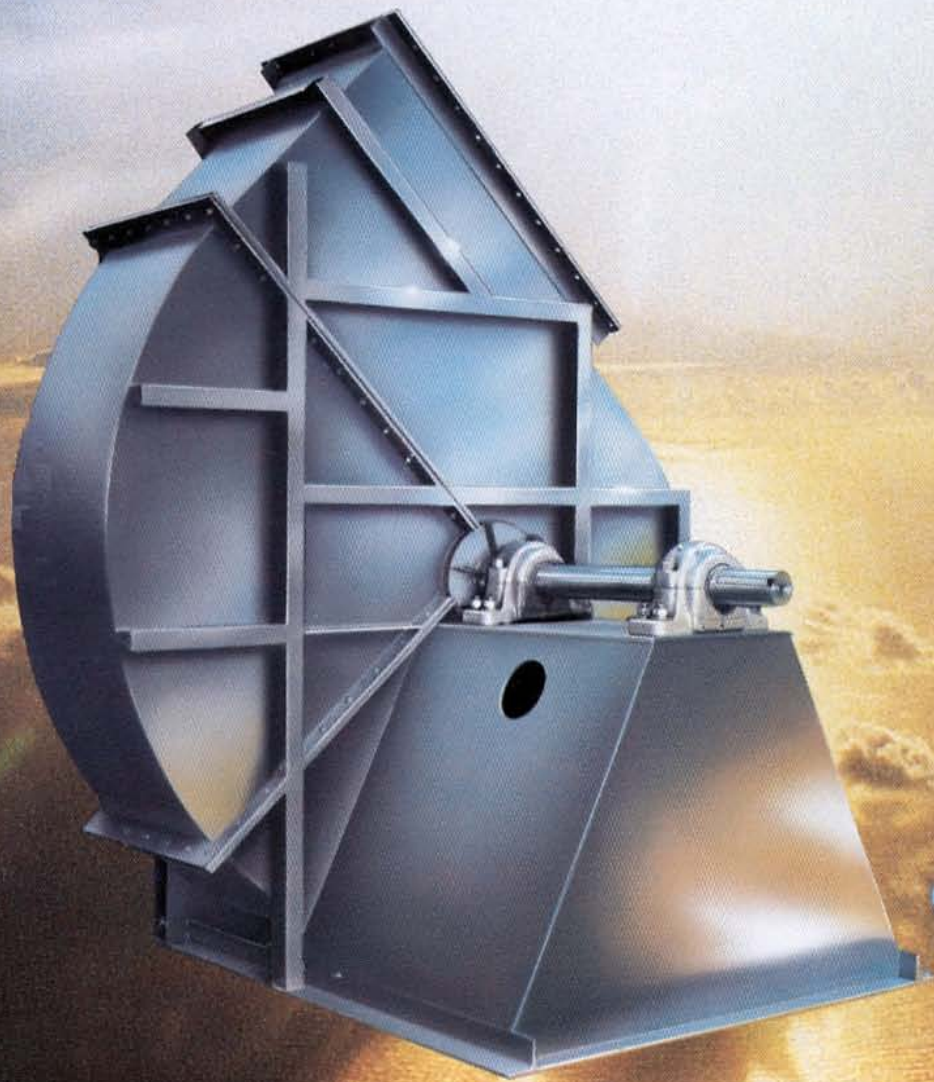

**IAF**  
INDUSTRIAL AIRFOIL  
**FANS**

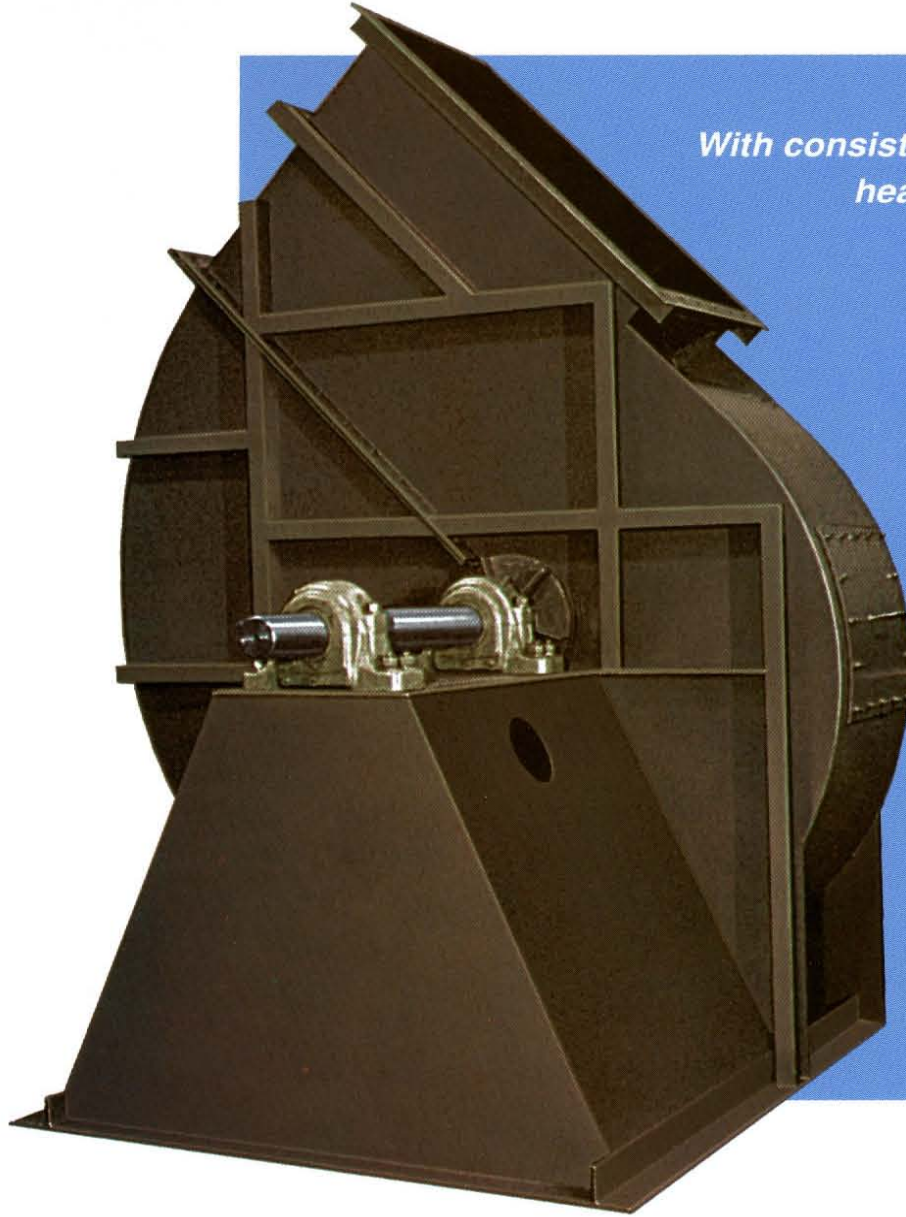

*With consistently high quality, rugged heavy duty construction and excellent efficiencies, Chicago's Industrial Airfoil Fan is the right choice for reliable, long term performance.*

## PERFORMANCE CHARACTERISTICS

- Sizes from 27" to 66"
- Over 80% static efficiency
- Capacities over 100,000 CFM
- Static pressures to over 30"
- Temperatures to 800°F
- Belt drive horsepowers to over 600

## CHICAGO INDUSTRIAL AIRFOIL FANS



### CHICAGO RELIABILITY

The IAF is a Chicago Industrial Airfoil Fan with proven performance and proven reliability through twenty years and hundreds of installations. Engineers and users enthusiastically specify the IAF for many high pressure applications, such as supply air, combustion air, product cooling and drying.

### STRUCTURAL INTEGRITY

The IAF is recognized for Chicago's all welded, true heavy duty construction. Housings are strongly braced to resist high pressure movement.. Shafts and bearings are sized for belt drive duty and provide years of uninterrupted life. Split pillow block roller bearings are standard on all IAF fans. Wheels are dynamically balanced for smoother running.

### HIGH EFFICIENCY

Deep spun inlet cones guide the air into the wheel and over its hollow airfoil shaped blades, providing maximum efficiency and minimum sound levels. Static efficiencies exceed 80%, reducing the energy needed to move each cubic foot of air.

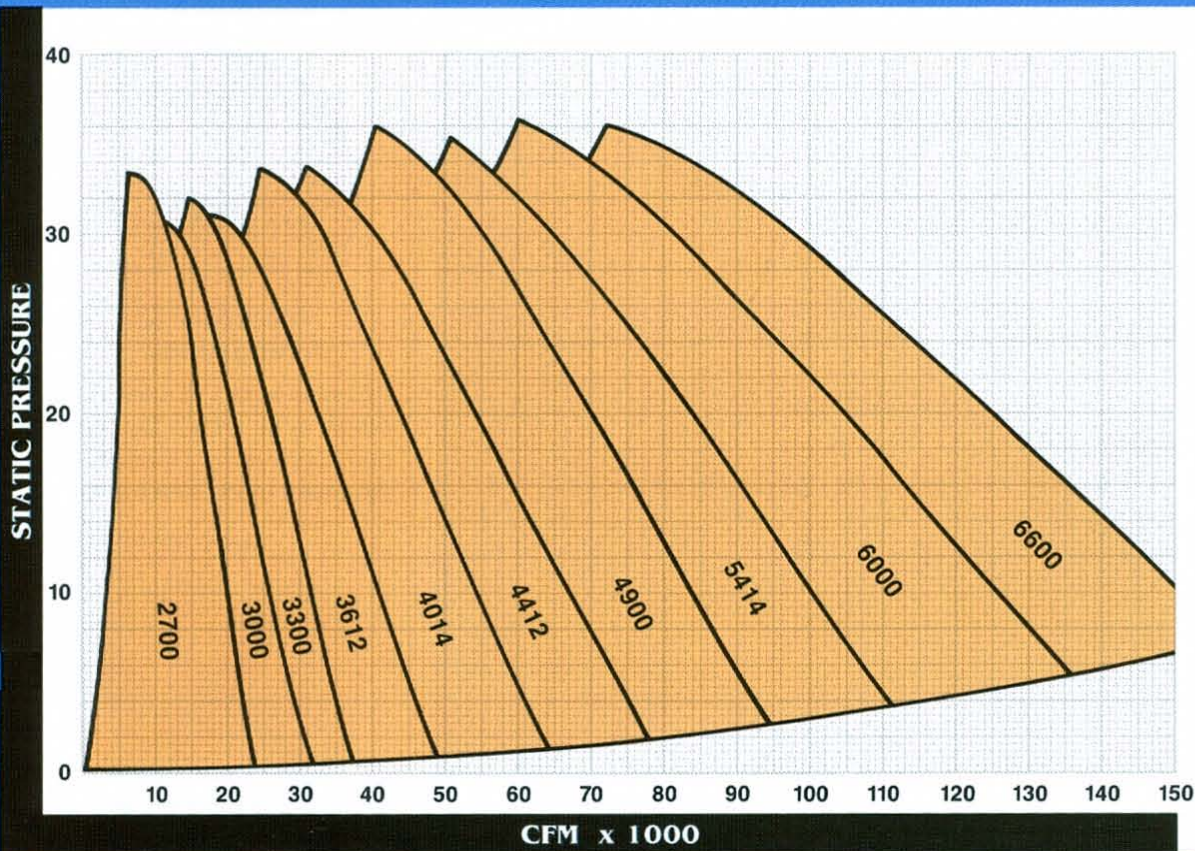

### QUICK SELECTION

Find the volume (CFM) desired along the bottom edge of the chart. Then move up vertically to the required static pressure. The envelope in which the intersecting lines meet is the optimum size IAF fan.

With the size established, turn to the **Rating Tables on pages 7 thru 11** to determine speed and brake horsepower.

If pressure requirements are at temperatures other than 70°F or at barometric pressures other than sea level, refer to **Table 1 and Table 2 on page 6.**

## WIDE PERFORMANCE RANGE

### PRE-ENGINEERED

Chicago's entire IAF fan line is completely pre-engineered. The primary benefits of pre-engineering include lower cost and greatly reduced lead times that assure speedier delivery to the job site.

### BELT DRIVE FLEXIBILITY

With belt drive the speed of the fan can be adjusted to provide the exact volume and pressure required. By combining belt drive with a selection of fan Sizes 2700 thru 6600, the IAF provides a wide performance range.

To simplify size selection, the Quick Selection chart shown above is useful to determine which IAF fan is best suited to application requirements.

*Chicago Sales Engineers located throughout America and around the world are available to provide application and selection assistance.*

## AIRFOIL BLADED WHEEL

The airfoil blades of Chicago's IAF fan are formed with steel dies to assure consistent uniformity. For high moisture applications two optional holes are stamped in each blade blank prior to forming. When the blades are folded over and welded these small weep holes allow moisture to escape from the hollow blade. It's this characteristic attention to design detail that helped build Chicago's reputation for reliability.



## DESIGN FEATURES

### STREAMLINED INLET FLANGED OUTLET

Airfoil fans are typically run in clean air applications drawing from the atmosphere. To effectively guide the air into the wheel, the IAF is designed with deep spun inlet cones. On the outlet side, a rigid punched flange is provided for easier connection to ductwork or system. Quick release inspection door, housing drain and shaft seal are also furnished standard.

### WELDED STEEL HOUSING

The scroll and side sheets of high grade steel are continuously welded to strict standards to maintain rigidity. Multiple stiffeners are then added before the entire housing is welded to the "A" frame bearing pedestal. The "A" frame base provides a wide, stable foundation to resist belt pull and associated vibration.

### OVERSIZED SHAFT AND BEARINGS

Shafts are sized for the maximum motor horsepower shown on the rating tables. At maximum speed and horsepower the shaft is using only 80% of its first critical speed. When smaller motors are used the safety factor is higher. Bearings have been selected for a minimum average life of 200,000 hours.

## BELT DRIVE ARRANGEMENTS

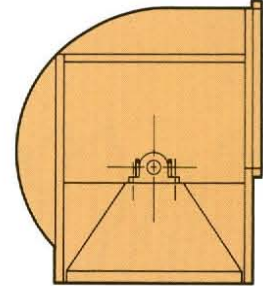

**Arrangement 1**

Arrangement 1 is often referred to as a bare fan. The customer usually mounts the motor along side the fan.

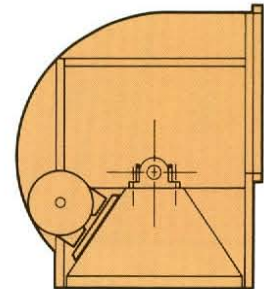

**Arrangement 9S**

On Arrangement 9S the motor is mounted on the side of the bearing pedestal. This is commonly known as a "packaged fan" and includes a factory run test of the entire drive train prior to shipment.

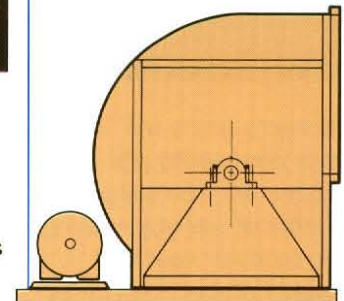

**Arrangement 9H**

Arrangement 9H covers motor frame sizes that are too large for pedestal mounting. The fan and motor are mounted on a unitary base fabricated from structural channel.

### CONSTRUCTION OPTIONS

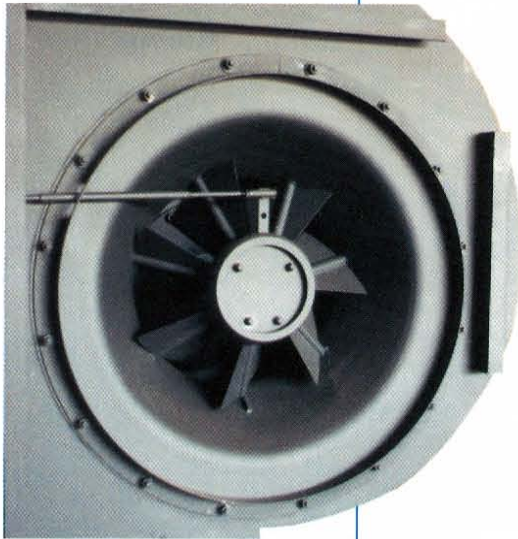

#### INLET VANE CONTROLS

Inlet vanes are an economical way to vary the air flow of the fan. The center control design provides low torque and smooth precise operation.



#### PUNCHED FLANGED INLETS

Punched flange inlet is a rolled ring that affords greater stiffness. This option simplifies bolted connections.

#### BELT GUARDS

V-belt drive guards are typically split and hinged for convenient inspection and maintenance. Guards can be painted yellow per customer request.

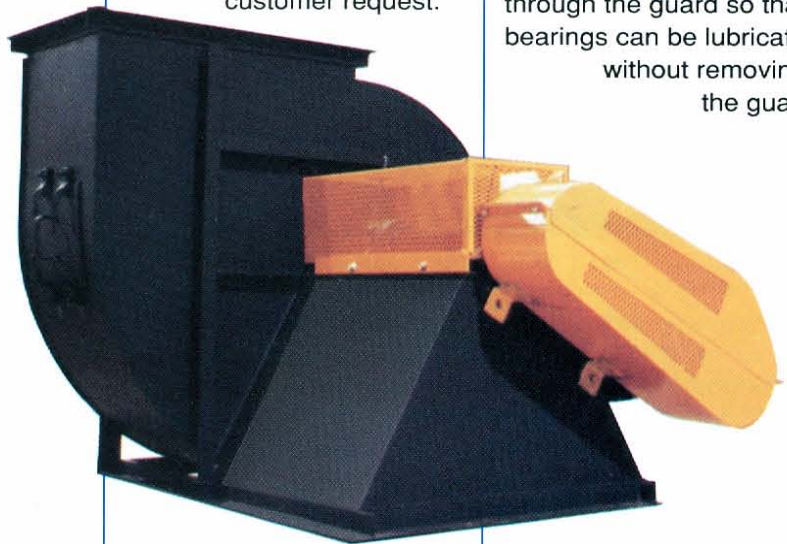

#### SHAFT AND BEARING GUARDS

OSHA guards protect workers from the rotating shaft and bearings. Grease fittings are then extended through the guard so that bearings can be lubricated without removing the guard.

#### ACCESS DOORS

Wide inspection doors are directly in line with the wheel. The standard door is securely held in place by quick release handles. Optional bolted design is also available.



#### *other options available*

- 
- **SHAFT SEALS**
- 
- **HOUSING DRAINS**
- 
- **SPLIT HOUSINGS**
- 
- **INLET SCREENS**
- 
- **BOLT-ON INLET BOXES**
- 
- **UNITARY BASES**

## IAF FAN SELECTION

### EXAMPLE:

1. Required: 20,000 CFM; 400°F.; 1500 feet elevation; 11.5" S.P.
2. Since Rating Tables are at sea level and 70°F. (.075 lb./ft.<sup>3</sup> density), convert required SP to equivalent SP at standard conditions using altitude and temperature correction factors from Table 1.

$$11.5 \times 1.72 = 19.78" \text{ SP}$$

3. From Rating Tables, select Size 3000 fan.
4. Interpolating from fan table, fan performance is:

Static Pressure	19		19.78		20	
	CFM	RPM	BHP	RPM	BHP	RPM
20,000	2634	81.2	2662	84.0	2670	84.8

5. Note that BHP as read from table is for handling air at .075 lb./ft.<sup>3</sup> density; for BHP at actual temperature and elevation, divide table BHP by altitude and temperature factor:

$$84.0 \div 1.72 = 48.8 \text{ BHP at conditions}$$

6. Check fan mechanical limitations: Since maximum wheel speed shown in Rating Table of 3072 RPM is at 70°F speed, deration factor for temperature from Table 2 of .95 must be used:

$$.95 \times 3072 = 2918 \text{ Maximum RPM at } 400^\circ\text{F.}$$

From Rating Table, maximum HP belt drive is 100, so even if fan is motored for cold start-up with 100 HP motor, Size 3000 fan is mechanically satisfactory.

TABLE 1:

Air Temp °F.	ALTITUDE AND TEMPERATURE CORRECTION FACTORS									
	ALTITUDE (Feet)									
	0	1000	1500	2000	2500	3000	3500	4000	4500	5000
0	.87	.91	.92	.94	.96	.98	.99	1.01	1.03	1.05
70	1.00	1.04	1.06	1.08	1.10	1.12	1.14	1.16	1.18	1.20
100	1.06	1.10	1.12	1.14	1.16	1.19	1.21	1.23	1.25	1.28
120	1.09	1.14	1.16	1.18	1.20	1.23	1.25	1.28	1.30	1.32
140	1.13	1.18	1.20	1.22	1.25	1.27	1.29	1.32	1.34	1.37
160	1.17	1.22	1.24	1.26	1.29	1.31	1.34	1.36	1.39	1.42
180	1.21	1.26	1.28	1.30	1.33	1.36	1.38	1.41	1.43	1.46
200	1.25	1.29	1.32	1.34	1.37	1.40	1.42	1.45	1.48	1.51
250	1.34	1.39	1.42	1.45	1.47	1.50	1.53	1.56	1.59	1.62
300	1.43	1.49	1.52	1.55	1.58	1.61	1.64	1.67	1.70	1.74
350	1.53	1.59	1.62	1.65	1.68	1.72	1.75	1.78	1.81	1.85
400	1.62	1.69	1.72	1.75	1.79	1.82	1.85	1.89	1.93	1.96
450	1.72	1.79	1.82	1.86	1.89	1.93	1.96	2.00	2.04	2.08
500	1.81	1.88	1.92	1.96	1.99	2.03	2.07	2.11	2.15	2.19
550	1.91	1.98	2.02	2.06	2.10	2.14	2.18	2.22	2.26	2.30
600	2.00	2.08	2.12	2.16	2.20	2.24	2.29	2.33	2.38	2.42
650	2.10	2.18	2.22	2.26	2.31	2.35	2.40	2.44	2.49	2.54
700	2.19	2.27	2.32	2.36	2.41	2.46	2.50	2.55	2.60	2.65
750	2.28	2.37	2.42	2.47	2.51	2.56	2.61	2.66	2.71	2.76
800	2.38	2.48	2.52	2.57	2.62	2.66	2.72	2.76	2.81	2.86

TABLE 2:

Temp °F.	TEMPERATURE / SPEED DERATION								
	70	100	200	300	400	500	600	700	800
Speed Deration Factor	100	.993	.964	.954	.943	.915	.884	.865	.828

Correction factors for temperature (F.) and altitude (feet above sea level), standard air = .075 lbs. per cubic foot at sea level, 29.92" barometric pressure and 70°F.

CONTACT YOUR LOCAL CHICAGO BLOWER SALES ENGINEER FOR SOFTWARE AND ASSISTANCE.



Refer to Chicago Blower's Selection Program, fan.net, for performance fan curves and sound data.

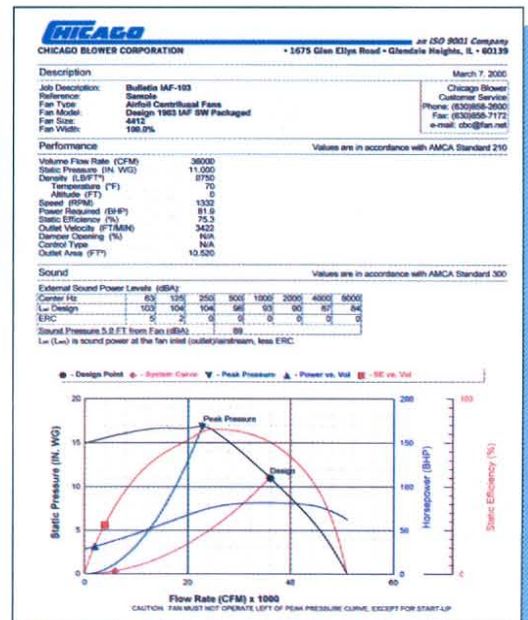



## SIZE **3300**

**WHEEL DIAMETER** 34.650 IN. **OUTLET AREA** 5.785 SQ. FT. **PEAK BHP** 7.254 (RPM/1000)<sup>3</sup>

**MAXIMUM RPM** 2783 **MAXIMUM MTR HP** 125

CFM	OUT VEL	11" SP		12" SP		13" SP		14" SP		15" SP		16" SP		17" SP		18" SP		19" SP		20" SP	
		RPM	BHP	RPM	BHP	RPM	BHP	RPM	BHP	RPM	BHP	RPM	BHP	RPM	BHP	RPM	BHP	RPM	BHP	RPM	BHP
11000	1901	1507	24.0	1558	26.2																
12000	2074	1545	26.4	1593	28.7	1640	31.0	1686	33.4												
14000	2420	1627	31.2	1673	33.9	1718	36.6	1762	39.3	1804	42.0	1845	44.6	1885	47.3	1925	50.0	1965	52.8	2005	55.8
16000	2766	1712	36.3	1757	39.4	1801	42.4	1844	45.5	1885	48.6	1925	51.6	1965	54.7	2003	57.8	2040	60.8	2077	63.9
18000	3111	1802	42.0	1846	45.3	1888	48.6	1929	52.0	1970	55.4	2009	58.8	2047	62.3	2085	65.7	2121	69.2	2157	72.6
20000	3457	1901	48.5	1940	52.0	1980	55.6	2019	59.2	2058	62.8	2096	66.5	2133	70.3	2170	74.0	2206	77.8	2241	81.6
22000	3803	2006	56.1	2043	59.7	2080	63.4	2116	67.2	2152	71.1	2188	75.0	2223	79.0	2258	83.0	2293	87.1	2327	91.2
24000	4149	2114	64.6	2150	68.5	2185	72.4	2219	76.4	2253	80.4	2286	84.5	2319	88.7	2352	92.9	2385	97.2	2418	101.5
26000	4494	2223	74.1	2259	78.3	2294	82.5	2327	86.7	2359	91.0	2391	95.3	2422	99.6	2453	104.0	2484	108.5	2514	113.0
28000	4840	2329	84.5	2367	89.1	2402	93.6	2436	98.2	2468	102.7	2499	107.3	2529	111.8	2558	116.4	2588	121.1	2616	125.8
30000	5186	2434	95.8	2473	100.8	2509	105.7	2544	110.6	2576	115.5	2607	120.4	2637	125.3	2667	130.1	2695	135.0	2723	139.9

CFM	OUT VEL	21" SP		22" SP		23" SP		24" SP		25" SP		26" SP		27" SP		28" SP		29" SP		30" SP	
		RPM	BHP	RPM	BHP	RPM	BHP	RPM	BHP	RPM	BHP	RPM	BHP	RPM	BHP	RPM	BHP	RPM	BHP	RPM	BHP
15000	2593	2075	62.5	2112	65.6	2150	68.8														
16000	2766	2112	66.9	2148	70.0	2182	73.1	2217	76.2	2252	79.5	2287	82.9								
17000	2939	2152	71.5	2187	74.8	2221	78.0	2254	81.2	2287	84.5	2320	87.7	2353	91.1	2386	94.5	2418	98.1	2452	101.8
18000	3111	2192	76.1	2227	79.6	2260	83.0	2294	86.5	2326	89.9	2358	93.3	2390	96.7	2421	100.2	2452	103.6	2483	107.2
20000	3457	2275	85.5	2309	89.3	2342	93.1	2375	97.0	2407	100.8	2438	104.7	2469	108.5	2500	112.4	2530	116.2	2559	120.0
22000	3803	2361	95.3	2394	99.5	2427	103.6	2459	107.8	2490	112.0	2521	116.2	2551	120.5	2581	124.7	2611	128.9	2640	133.2
24000	4149	2450	105.9	2482	110.3	2514	114.8	2545	119.3	2576	123.8	2606	128.3	2636	132.9	2666	137.4	2695	142.0	2723	146.6

## SIZE **3612**

**WHEEL DIAMETER** 38.325 IN. **OUTLET AREA** 7.077 SQ. FT. **PEAK BHP** 13.205 (RPM/1000)<sup>3</sup>

**MAXIMUM RPM** 2361 **MAXIMUM MTR HP** 150

CFM	OUT VEL	11" SP		12" SP		13" SP		14" SP		15" SP		16" SP		17" SP		18" SP		19" SP		20" SP	
		RPM	BHP	RPM	BHP	RPM	BHP	RPM	BHP	RPM	BHP	RPM	BHP	RPM	BHP	RPM	BHP	RPM	BHP	RPM	BHP
14000	1978	1347	30.3	1394	33.1	1441	36.1														
16000	2261	1396	34.9	1440	37.9	1483	41.0	1524	44.2	1565	47.3	1606	50.5	1648	53.9						
18000	2543	1449	39.7	1491	43.1	1533	46.5	1573	49.9	1613	53.4	1651	56.9	1688	60.4	1725	63.8	1761	67.4	1798	71.0
20000	2826	1506	44.9	1547	48.6	1587	52.3	1626	56.0	1664	59.8	1701	63.6	1738	67.4	1774	71.2	1809	75.1	1843	79.0
22000	3109	1566	50.7	1606	54.6	1645	58.6	1682	62.6	1719	66.6	1755	70.7	1791	74.8	1825	78.9	1859	83.1	1893	87.3
24000	3391	1628	57.0	1667	61.2	1705	65.4	1742	69.7	1778	74.0	1813	78.3	1847	82.7	1881	87.1	1914	91.6	1946	96.1
26000	3674	1692	64.0	1730	68.4	1767	72.9	1803	77.4	1838	82.0	1872	86.6	1906	91.3	1939	95.9	1971	100.7	2002	105.4
28000	3956	1758	71.6	1795	76.3	1831	81.0	1866	85.8	1901	90.7	1934	95.5	1967	100.5	1999	105.4	2030	110.4	2061	115.4
32000	4522	1895	89.0	1930	94.2	1964	99.5	1997	104.9	2030	110.2	2062	115.7	2094	121.1	2124	126.6	2155	132.1	2184	137.6
36000	5087	2038	109.7	2071	115.5	2103	121.3	2134	127.2	2165	133.1	2196	139.0	2226	145.0	2255	151.0	2284	157.1	2313	163.1
40000	5652	2190	134.1	2219	140.4	2248	146.7	2277	153.2	2306	159.6	2335	166.1								

CFM	OUT VEL	21" SP		22" SP		23" SP		24" SP		25" SP		26" SP		27" SP		28" SP		29" SP		30" SP	
		RPM	BHP	RPM	BHP	RPM	BHP	RPM	BHP	RPM	BHP	RPM	BHP	RPM	BHP	RPM	BHP	RPM	BHP	RPM	BHP
18000	2543	1834	74.7	1872	78.6																
20000	2826	1877	82.8	1909	86.7	1942	90.6	1975	94.6	2007	98.7	2041	102.8	2074	107.1						
22000	3109	1926	91.5	1958	95.7	1990	100.0	2021	104.2	2052	108.5	2082	112.8	2112	117.0	2141	121.4	2171	125.8	2201	130.2
24000	3391	1978	100.6	2010	105.1	2041	109.7	2071	114.2	2101	118.8	2131	123.5	2160	128.1	2189	132.7	2217	137.4	2245	142.0
26000	3674	2033	110.2	2064	115.0	2094	119.8	2124	124.7	2153	129.6	2182	134.5	2211	139.5	2239	144.4	2267	149.4	2294	154.4
28000	3956	2091	120.5	2121	125.5	2151	130.6	2180	135.8	2208	141.0	2236	146.2	2264	151.4	2292	156.6	2319	161.9	2346	167.2
32000	4522	2213	143.2	2242	148.8	2270	154.4	2298	160.1	2325	165.8	2352	171.6								



# SIZE 4014

WHEEL DIAMETER 42.262 IN.    OUTLET AREA 8.606 SQ. FT.    PEAK BHP 21.533 (RPM/1000)<sup>3</sup>

MAXIMUM RPM 2111    MAXIMUM MTR HP 200

CFM	OUT VEL	11" SP		12" SP		13" SP		14" SP		15" SP		16" SP		17" SP		18" SP		19" SP		20" SP	
		RPM	BHP	RPM	BHP	RPM	BHP	RPM	BHP	RPM	BHP	RPM	BHP	RPM	BHP	RPM	BHP	RPM	BHP	RPM	BHP
18000	2092	1239	39.1	1280	42.6	1320	46.1	1360	49.8	1401	53.7										
20000	2324	1276	43.7	1316	47.5	1354	51.4	1392	55.2	1428	59.1	1464	63.1	1500	67.1	1537	71.3				
22000	2556	1316	48.5	1355	52.7	1392	56.8	1429	61.0	1464	65.3	1499	69.5	1533	73.8	1566	78.0	1599	82.4	1632	86.8
24000	2789	1359	53.8	1396	58.2	1432	62.6	1468	67.1	1503	71.6	1537	76.2	1570	80.8	1602	85.4	1634	90.1	1665	94.7
26000	3021	1403	59.4	1439	64.1	1475	68.8	1509	73.6	1543	78.4	1576	83.2	1609	88.1	1641	93.0	1672	98.0	1702	103.0
30000	3486	1496	72.1	1531	77.3	1565	82.5	1598	87.8	1630	93.2	1662	98.5	1692	104.0	1723	109.5	1752	115.0	1782	120.5
34000	3951	1593	86.8	1627	92.6	1659	98.3	1691	104.2	1722	110.0	1753	116.0	1782	121.9	1812	127.9	1840	134.0	1868	140.1
38000	4416	1694	104.0	1726	110.2	1758	116.5	1788	122.9	1818	129.3	1848	135.8	1877	142.3	1905	148.8	1932	155.4	1959	162.0
42000	4880	1800	123.7	1830	130.5	1860	137.3	1889	144.2	1918	151.2	1946	158.2	1974	165.2	2001	172.3	2028	179.4	2054	186.6
46000	5345	1911	146.3	1938	153.7	1966	161.1	1994	168.5	2021	176.0	2048	183.5	2075	191.1	2101	198.7				
50000	5810	2026	172.2	2051	180.0	2077	188.0	2102	195.9												

CFM	OUT VEL	21" SP		22" SP		23" SP		24" SP		25" SP		26" SP		27" SP		28" SP		29" SP		30" SP	
		RPM	BHP	RPM	BHP	RPM	BHP	RPM	BHP	RPM	BHP	RPM	BHP	RPM	BHP	RPM	BHP	RPM	BHP	RPM	BHP
22000	2556	1665	91.3	1698	96.0																
24000	2789	1696	99.4	1726	104.0	1756	108.8	1786	113.6	1816	118.6	1847	123.7	1879	129.0						
26000	3021	1732	108.0	1762	113.0	1791	118.0	1819	123.1	1847	128.1	1875	133.2	1903	138.3	1930	143.6	1958	148.9	1986	154.4
28000	3254	1770	116.9	1799	122.2	1828	127.6	1856	132.9	1883	138.3	1910	143.7	1937	149.2	1963	154.6	1989	160.0	2015	165.5
32000	3718	1852	135.9	1880	141.8	1907	147.8	1934	153.7	1960	159.7	1986	165.8	2012	171.8	2038	177.9	2063	184.0	2088	190.2
36000	4183	1940	157.1	1967	163.6	1993	170.0	2019	176.5	2044	183.1	2069	189.7	2094	196.3						
40000	4648	2033	180.8	2058	187.8	2084	194.8	2109	201.9												

# SIZE 4412

WHEEL DIAMETER 46.725 IN.    OUTLET AREA 10.520 SQ. FT.    PEAK BHP 35.569 (RPM/1000)<sup>3</sup>

MAXIMUM RPM 2009    MAXIMUM MTR HP 200

CFM	OUT VEL	11" SP		12" SP		13" SP		14" SP		15" SP		16" SP		17" SP		18" SP		19" SP		20" SP	
		RPM	BHP	RPM	BHP	RPM	BHP	RPM	BHP	RPM	BHP	RPM	BHP	RPM	BHP	RPM	BHP	RPM	BHP	RPM	BHP
20000	1901	1095	43.4	1135	47.5																
24000	2281	1148	52.3	1184	56.9	1219	61.6	1253	66.2	1286	70.9	1320	75.7	1353	80.7	1388	86.0				
28000	2662	1208	62.2	1242	67.4	1276	72.6	1308	77.9	1340	83.3	1371	88.6	1402	94.0	1431	99.5	1460	104.9	1489	110.4
32000	3042	1273	73.3	1306	79.0	1338	84.8	1369	90.6	1399	96.5	1429	102.5	1458	108.5	1487	114.6	1515	120.7	1543	126.8
36000	3422	1341	85.8	1373	92.1	1404	98.4	1434	104.8	1463	111.2	1492	117.7	1520	124.3	1548	130.9	1575	137.6	1601	144.3
40000	3802	1413	100.1	1443	106.9	1473	113.7	1503	120.7	1531	127.6	1559	134.7	1586	141.7	1612	148.9	1638	156.1	1664	163.3
44000	4183	1486	116.2	1516	123.5	1545	130.9	1573	138.4	1601	145.9	1628	153.4	1654	161.0	1680	168.7	1706	176.4	1730	184.2
48000	4563	1563	134.4	1591	142.2	1619	150.2	1646	158.1	1673	166.2	1699	174.3	1725	182.4	1750	190.6	1775	198.9	1799	207.2
52000	4943	1641	154.7	1668	163.1	1695	171.6	1721	180.1	1747	188.7	1773	197.3	1797	206.0	1822	214.7	1846	223.5	1870	232.4
56000	5323	1723	177.5	1749	186.4	1774	195.4	1799	204.5	1824	213.6	1848	222.8	1872	232.0	1896	241.3	1919	250.6	1942	260.0
60000	5703	1808	202.9	1832	212.4	1855	221.9	1879	231.5	1902	241.1	1926	250.8	1949	260.6	1972	270.4	1994	280.3		

CFM	OUT VEL	21" SP		22" SP		23" SP		24" SP		25" SP		26" SP		27" SP		28" SP		29" SP		30" SP	
		RPM	BHP	RPM	BHP	RPM	BHP	RPM	BHP	RPM	BHP	RPM	BHP	RPM	BHP	RPM	BHP	RPM	BHP	RPM	BHP
26000	2471	1499	108.5																		
28000	2662	1517	115.9	1546	121.5	1575	127.3	1604	133.4												
32000	3042	1570	132.9	1596	139.1	1623	145.3	1648	151.5	1674	157.7	1699	164.0	1723	170.3	1748	176.6	1773	183.1	1798	189.8
36000	3422	1627	151.0	1653	157.8	1678	164.6	1703	171.5	1728	178.4	1752	185.3	1776	192.2	1800	199.1	1823	206.1	1846	213.1
40000	3802	1689	170.6	1714	177.9	1739	185.3	1763	192.7	1786	200.2	1810	207.7	1833	215.3	1856	222.8	1878	230.4	1901	238.1
44000	4183	1755	192.0	1779	199.9	1803	207.8	1826	215.8	1849	223.8	1872	231.8	1894	239.9	1916	248.1	1938	256.2	1960	264.4
48000	4563	1823	215.5	1846	223.9	1869	232.3	1892	240.8	1915	249.4	1937	257.9	1958	266.6	1980	275.2	2001	283.9		

### SIZE **4900**

**WHEEL DIAMETER**  
51.450 IN.

**OUTLET AREA**  
12.755 SQ. FT.

**PEAK BHP**  
57.578 (RPM/1000)<sup>3</sup>

**MAXIMUM RPM** 1850  
**MAXIMUM MTR HP** 250

CFM	OUT VEL	11" SP		12" SP		13" SP		14" SP		15" SP		16" SP		17" SP		18" SP		19" SP		20" SP	
		RPM	BHP	RPM	BHP	RPM	BHP	RPM	BHP	RPM	BHP	RPM	BHP	RPM	BHP	RPM	BHP	RPM	BHP	RPM	BHP
26000	2038	1011	56.4	1045	61.5	1078	66.7	1113	72.2												
30000	2352	1052	65.6	1085	71.3	1116	77.1	1147	82.9	1177	88.7	1206	94.6	1235	100.6	1265	106.8	1295	113.3		
34000	2666	1097	75.5	1129	81.8	1159	88.2	1189	94.6	1218	101.1	1246	107.6	1273	114.2	1300	120.8	1327	127.4	1353	134.0
38000	2979	1146	86.5	1176	93.3	1205	100.2	1234	107.2	1262	114.3	1289	121.4	1316	128.6	1342	135.8	1367	143.1	1393	150.4
42000	3293	1197	98.7	1226	106.0	1254	113.5	1282	121.0	1309	128.6	1335	136.3	1361	144.0	1386	151.8	1411	159.6	1436	167.5
46000	3606	1249	112.2	1278	120.1	1305	128.1	1332	136.1	1358	144.2	1384	152.4	1409	160.7	1434	169.0	1458	177.4	1481	185.9
50000	3920	1303	127.2	1331	135.6	1358	144.1	1384	152.7	1410	161.3	1435	170.1	1459	178.8	1483	187.7	1507	196.6	1530	205.6
54000	4234	1359	143.7	1386	152.7	1412	161.7	1438	170.8	1463	180.0	1487	189.3	1511	198.6	1534	208.0	1557	217.4	1580	226.9
60000	4704	1445	171.8	1471	181.5	1496	191.4	1520	201.3	1544	211.3	1568	221.4	1591	231.5	1613	241.7	1636	251.9	1658	262.2
66000	5174	1536	204.0	1559	214.6	1583	225.3	1606	236.0	1629	246.8	1651	257.7	1673	268.6	1695	279.6	1717	290.6	1738	301.7
72000	5645	1630	241.0	1652	252.4	1673	263.9	1695	275.4	1716	287.0	1738	298.7	1759	310.4	1780	322.2	1801	334.0	1821	346.0

CFM	OUT VEL	21" SP		22" SP		23" SP		24" SP		25" SP		26" SP		27" SP		28" SP		29" SP		30" SP	
		RPM	BHP	RPM	BHP	RPM	BHP	RPM	BHP	RPM	BHP	RPM	BHP	RPM	BHP	RPM	BHP	RPM	BHP	RPM	BHP
32000	2509	1364	133.2																		
36000	2822	1397	149.1	1422	156.1	1446	163.2	1471	170.3	1495	177.6	1520	185.1	1545	192.9						
40000	3136	1438	166.5	1462	174.2	1486	181.9	1509	189.6	1532	197.3	1554	205.1	1576	212.9	1598	220.7	1620	228.6	1642	236.6
44000	3450	1482	184.8	1505	193.0	1528	201.4	1551	209.7	1573	218.1	1595	226.6	1617	235.0	1638	243.5	1659	252.0	1680	260.5
48000	3763	1528	204.3	1551	213.1	1573	222.0	1595	231.0	1617	239.9	1638	249.0	1659	258.1	1680	267.2	1701	276.3	1721	285.5
52000	4077	1577	225.4	1599	234.7	1621	244.1	1642	253.6	1663	263.1	1684	272.7	1704	282.4	1725	292.0	1745	301.8	1764	311.5
58000	4547	1653	260.1	1674	270.2	1695	280.4	1716	290.7	1736	301.0	1756	311.4	1776	321.8	1796	332.3	1815	342.8	1834	353.4

### SIZE **5414**

**WHEEL DIAMETER**  
56.962 IN.

**OUTLET AREA**  
15.634 SQ. FT.

**PEAK BHP**  
95.779 (RPM/1000)<sup>3</sup>

**MAXIMUM RPM** 1659  
**MAXIMUM MTR HP** 300

CFM	OUT VEL	11" SP		12" SP		13" SP		14" SP		15" SP		16" SP		17" SP		18" SP		19" SP		20" SP	
		RPM	BHP	RPM	BHP	RPM	BHP	RPM	BHP	RPM	BHP	RPM	BHP	RPM	BHP	RPM	BHP	RPM	BHP	RPM	BHP
30000	1919	900	65.0	933	71.2																
35000	2239	936	76.2	966	83.0	995	89.8	1023	96.6	1051	103.5	1079	110.6	1107	118.1						
40000	2559	977	88.3	1005	95.8	1033	103.3	1060	111.0	1087	118.7	1113	126.4	1138	134.1	1162	141.9	1187	149.8	1211	157.8
45000	2878	1020	101.5	1048	109.7	1075	118.0	1101	126.3	1126	134.8	1151	143.3	1176	151.8	1200	160.4	1223	169.1	1246	177.8
50000	3198	1067	116.3	1093	125.1	1119	134.0	1144	143.1	1169	152.2	1193	161.4	1217	170.6	1240	180.0	1262	189.4	1285	198.9
55000	3518	1115	132.7	1141	142.2	1166	151.8	1190	161.4	1214	171.2	1237	181.1	1260	191.0	1283	201.0	1304	211.1	1326	221.3
60000	3838	1164	150.9	1189	161.0	1214	171.3	1238	181.6	1261	192.1	1284	202.6	1306	213.2	1328	223.9	1349	234.6	1370	245.5
67000	4286	1236	179.7	1260	190.8	1283	202.0	1306	213.3	1329	224.7	1351	236.1	1373	247.6	1394	259.2	1414	270.9	1434	282.7
74000	4733	1310	212.8	1333	224.9	1356	237.0	1378	249.2	1399	261.5	1421	273.9	1441	286.4	1462	298.9	1482	311.5	1502	324.2
81000	5181	1388	250.7	1409	263.7	1431	276.8	1452	289.9	1472	303.2	1492	316.5	1513	329.9	1532	343.4	1552	356.9	1571	370.6
88000	5629	1469	293.8	1489	307.7	1508	321.7	1528	335.8	1548	350.0	1567	364.2	1586	378.6	1605	393.0	1624	407.5	1642	422.1

CFM	OUT VEL	21" SP		22" SP		23" SP		24" SP		25" SP		26" SP		27" SP		28" SP		29" SP		30" SP	
		RPM	BHP	RPM	BHP	RPM	BHP	RPM	BHP	RPM	BHP	RPM	BHP	RPM	BHP	RPM	BHP	RPM	BHP	RPM	BHP
40000	2559	1235	166.0	1260	174.5																
45000	2878	1268	186.5	1291	195.2	1312	204.0	1334	212.8	1355	221.8	1377	230.9	1399	240.3	1421	250.0				
50000	3198	1307	208.4	1328	218.0	1349	227.6	1370	237.2	1391	246.8	1411	256.5	1431	266.2	1450	275.9	1470	285.7	1489	295.6
55000	3518	1347	231.5	1368	241.8	1389	252.2	1409	262.6	1429	273.1	1449	283.6	1468	294.1	1487	304.7	1506	315.3	1525	325.9
60000	3838	1391	256.4	1411	267.4	1431	278.4	1451	289.5	1470	300.7	1489	311.9	1508	323.2	1527	334.6	1545	346.0	1564	357.4
65000	4158	1436	283.2	1456	294.8	1475	306.5	1494	318.3	1513	330.2	1532	342.1	1550	354.1	1568	366.1	1586	378.2	1604	390.3
70000	4477	1483	312.1	1502	324.5	1521	336.8	1540	349.3	1558	361.8	1576	374.3	1594	387.0	1612	399.7	1630	412.5	1647	425.3

**SIZE 6000**
**WHEEL DIAMETER** 63.000 IN.    **OUTLET AREA** 19.124 SQ. FT.    **PEAK BHP** 158.500 (RPM/1000)<sup>3</sup>
**MAXIMUM RPM** 1526    **MAXIMUM MTR HP** 400

CFM	OUT VEL	11" SP		12" SP		13" SP		14" SP		15" SP		16" SP		17" SP		18" SP		19" SP		20" SP	
		RPM	BHP	RPM	BHP	RPM	BHP	RPM	BHP	RPM	BHP	RPM	BHP	RPM	BHP	RPM	BHP	RPM	BHP	RPM	BHP
38000	1987	820	82.4	848	89.9	877	97.8														
45000	2353	859	98.4	886	107.0	912	115.6	937	124.3	961	133.1	985	141.9	1009	150.9	1033	160.2	1058	169.9		
52000	2719	903	115.9	928	125.5	953	135.2	977	145.0	1000	154.9	1023	164.8	1046	174.8	1068	184.9	1089	194.9	1110	205.0
59000	3085	950	135.6	974	146.2	997	156.8	1021	167.6	1043	178.4	1065	189.4	1087	200.4	1108	211.5	1129	222.7	1149	234.0
66000	3451	999	157.9	1022	169.4	1045	180.9	1067	192.6	1089	204.4	1110	216.3	1131	228.3	1151	240.4	1171	252.6	1191	264.8
73000	3817	1050	183.1	1073	195.4	1095	207.9	1116	220.5	1137	233.2	1158	246.1	1178	259.0	1198	272.0	1217	285.1	1236	298.3
80000	4183	1102	211.3	1124	224.6	1146	238.1	1167	251.6	1187	265.3	1207	279.0	1227	292.8	1246	306.8	1265	320.8	1283	334.9
87000	4549	1157	243.0	1178	257.3	1199	271.7	1219	286.1	1239	300.7	1258	315.4	1277	330.2	1296	345.0	1315	360.0	1333	375.0
94000	4915	1213	278.4	1233	293.6	1253	309.0	1273	324.4	1292	339.9	1311	355.5	1329	371.2	1347	387.0	1365	402.9	1383	418.9
101000	5281	1271	317.9	1290	334.0	1309	350.3	1328	366.6	1346	383.1	1364	399.7	1382	416.3	1400	433.1	1417	449.9	1434	466.8
108000	5647	1332	361.7	1349	378.8	1367	395.9	1385	413.2	1402	430.6	1420	448.1	1437	465.8	1454	483.4	1471	501.2	1487	519.1

CFM	OUT VEL	21" SP		22" SP		23" SP		24" SP		25" SP		26" SP		27" SP		28" SP		29" SP		30" SP	
		RPM	BHP	RPM	BHP	RPM	BHP	RPM	BHP	RPM	BHP	RPM	BHP	RPM	BHP	RPM	BHP	RPM	BHP	RPM	BHP
50000	2615	1121	207.1	1143	217.4	1165	228.1														
56000	2928	1152	232.2	1172	243.1	1192	254.0	1211	264.8	1230	275.9	1249	287.1	1268	298.4	1288	310.2	1308	322.2		
62000	3242	1186	258.7	1206	270.5	1225	282.4	1244	294.3	1262	306.3	1280	318.3	1298	330.3	1316	342.3	1333	354.3	1351	366.5
68000	3556	1223	286.7	1242	299.4	1260	312.2	1278	325.0	1296	337.9	1314	350.9	1332	363.9	1349	376.9	1366	390.0	1383	403.1
74000	3869	1261	316.8	1280	330.3	1298	343.9	1315	357.5	1333	371.3	1350	385.1	1367	399.0	1384	413.0	1401	427.0	1417	441.0
80000	4183	1302	349.2	1319	363.4	1337	377.8	1354	392.3	1371	406.9	1388	421.5	1405	436.2	1421	451.0	1437	465.9	1453	480.8
86000	4497	1343	384.1	1361	399.2	1378	414.4	1395	429.6	1411	445.0	1428	460.4	1444	475.9	1460	491.5	1476	507.2	1492	522.9

**SIZE 6600**
**WHEEL DIAMETER** 69.300 IN.    **OUTLET AREA** 23.140 SQ. FT.    **PEAK BHP** 255.266 (RPM/1000)<sup>3</sup>
**MAXIMUM RPM** 1377    **MAXIMUM MTR HP** 400

CFM	OUT VEL	11" SP		12" SP		13" SP		14" SP		15" SP		16" SP		17" SP		18" SP		19" SP		20" SP	
		RPM	BHP	RPM	BHP	RPM	BHP	RPM	BHP	RPM	BHP	RPM	BHP	RPM	BHP	RPM	BHP	RPM	BHP	RPM	BHP
46000	1988	746	99.7	771	108.8	797	118.4														
54000	2334	779	118.0	803	128.3	827	138.7	850	149.2	872	159.6	894	170.3	916	181.1	938	192.4				
62000	2679	816	137.8	839	149.3	862	160.9	884	172.7	905	184.5	926	196.3	947	208.3	967	220.3	986	232.3	1005	244.3
70000	3025	856	160.0	878	172.5	900	185.2	921	198.1	942	211.0	962	224.1	982	237.3	1001	250.5	1020	263.9	1038	277.3
78000	3371	898	184.9	920	198.5	940	212.2	961	226.1	981	240.1	1000	254.3	1019	268.5	1038	282.9	1056	297.4	1074	312.0
86000	3717	941	212.8	962	227.4	983	242.2	1002	257.2	1022	272.2	1041	287.5	1059	302.8	1077	318.2	1095	333.8	1112	349.4
94000	4062	986	243.9	1006	259.7	1026	275.6	1045	291.6	1064	307.7	1083	324.0	1101	340.3	1118	356.8	1135	373.4	1152	390.2
103000	4451	1038	283.3	1058	300.3	1077	317.4	1095	334.6	1114	351.9	1131	369.4	1149	387.0	1166	404.6	1183	422.4	1199	440.4
112000	4840	1092	327.7	1111	345.9	1129	364.2	1147	382.6	1164	401.1	1182	419.8	1199	438.6	1215	457.5	1232	476.5	1248	495.6
121000	5229	1148	377.5	1165	396.9	1183	416.4	1200	436.0	1217	455.8	1233	475.6	1250	495.6	1266	515.7	1282	536.0	1297	556.3
130000	5618	1206	433.2	1222	453.7	1238	474.4	1254	495.2	1271	516.2	1286	537.3	1302	558.5	1318	579.8	1333	601.3	1348	622.8

CFM	OUT VEL	21" SP		22" SP		23" SP		24" SP		25" SP		26" SP		27" SP		28" SP		29" SP		30" SP	
		RPM	BHP	RPM	BHP	RPM	BHP	RPM	BHP	RPM	BHP	RPM	BHP	RPM	BHP	RPM	BHP	RPM	BHP	RPM	BHP
58000	2506	1012	241.4																		
65000	2809	1036	269.2	1054	281.8	1073	294.6	1091	307.6	1109	320.8	1127	334.5	1146	348.7						
72000	3111	1065	299.5	1083	313.3	1101	327.2	1118	341.1	1135	355.1	1152	369.1	1168	383.1	1185	397.3	1201	411.6	1217	426.1
80000	3457	1101	336.0	1118	351.1	1135	366.2	1152	381.4	1169	396.7	1185	412.0	1201	427.4	1217	442.8	1232	458.2	1248	473.7
88000	3803	1139	375.3	1156	391.5	1172	407.7	1188	424.1	1205	440.5	1220	457.0	1236	473.6	1251	490.3	1267	507.0	1282	523.8
96000	4149	1179	418.0	1195	435.2	1211	452.5	1227	469.9	1243	487.4	1258	505.0	1273	522.7	1288	540.5	1303	558.4	1318	576.3
104000	4494	1221	464.4	1237	482.6	1252	501.0	1268	519.5	1283	538.0	1298	556.7	1312	575.5	1327	594.3	1341	613.3	1356	632.3

### SOUND DATA

**NOTES:**

1. Ratings are based on sound tests in accordance with AMCA sound code 300 set-up 1 in an AMCA sound approved laboratory.
2. Values shown are for total internal sound power level re  $10^{-12}$  watt per AMCA Bulletin 301 and 303.
3. dBA value applies to 10 foot distance based on theoretical free field environment.
4. Ratings apply to normal range of selection for high efficiency, as shown in capacity tables.
5. For Sound Pressure at various distances, subtract the following dB (based on free field conditions):

Distance	dB subtract
3'	- 11
5'	- 15
10'	- 21
50'	- 35
100'	- 41

6. Octave band center frequency in Hz, are per ANSI SI.6-1960 and AMCA series 2.

**CURVE 1:**

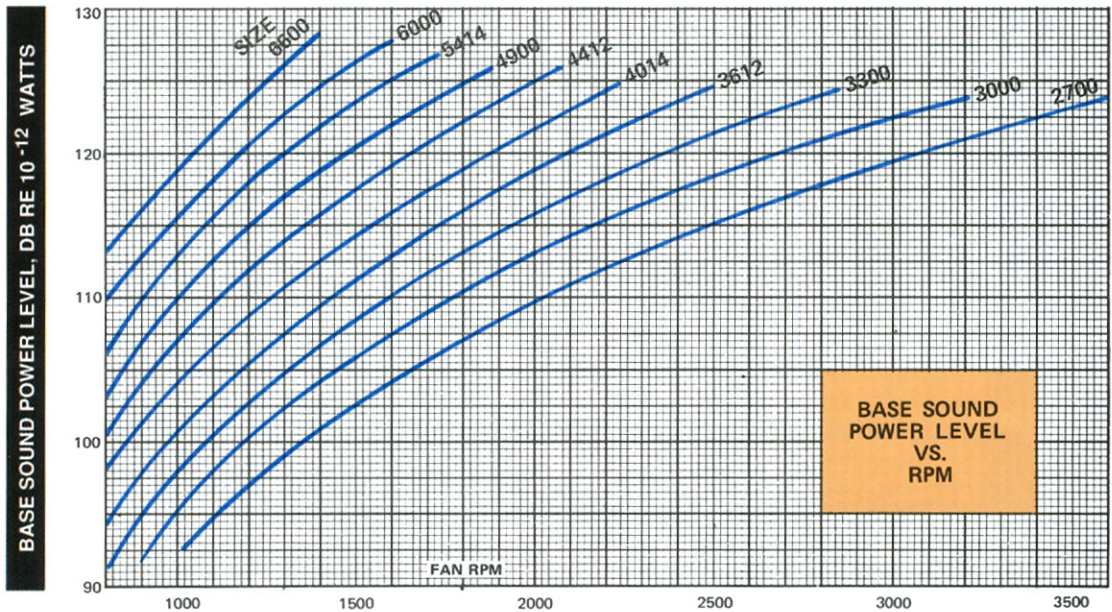

**TABLE 1:**

**OCTAVE BAND CONVERSION AT VARIOUS RPM'S**

OCTAVE CENTER HZ		1 63	2 125	3 250	4 500	5 1000	6 2000	7 4000	8 8000	Theoretical dBA Correction
RPM	828	-4	-3	-10	-17	-20	-23	-25	-28	-33
	900	-4	-3	-9	-17	-20	-22	-25	-28	-33
	1035	-4	-4	-8	-16	-20	-22	-25	-28	-32
	1200	-4	-6	-6	-15	-20	-23	-25	-28	-32
	1380	-4	-7	-5	-15	-21	-23	-25	-28	-31
	1500	-4	-7	-5	-14	-20	-23	-25	-28	-31
	1600	-3	-7	-5	-14	-20	-23	-25	-28	-31
	1800	-3	-7	-6	-12	-20	-23	-25	-28	-31
	2070	-3	-6	-7	-10	-19	-23	-25	-28	-30
	2800	-5	-5	-9	-6	-17	-22	-25	-27	-27
	3200	-6	-5	-9	-7	-15	-21	-24	-27	-27
	3600	-7	-4	-8	-7	-13	-21	-24	-26	-27

**PROCEDURE:**

Enter dB chart at fan RPM and read vertically up to fan size. Resulting dB value is then used as a base from which octave band values may be obtained by applying corrections shown on the table at this RPM. Similarly, apply dBA correction to this base sound power level to obtain dBA.

**EXAMPLE:**

Assume a size 3612 at 2000 RPM. Enter Curve 1 above at 2000 RPM and read base dB value of 119 dB. For octave band analysis, use conversions in Table 1:

OCTAVE BAND:	1	2	3	4	5	6	7	8
Base	119	119	119	119	119	119	119	119
Conversion	-3	-6	-7	-10	-19	-23	-25	-28
Sound Power Level (dB re $10^{-12}$ Watts)	116	113	112	109	100	96	94	91

If fan were open inlet or discharge, dBA value at 10 feet in a theoretical free field environment could be obtained by subtracting theoretical dBA correction from base:

**119 - 30 = 89 dBA**

More absolute sound information is available from local Chicago Blower offices.

### DIMENSIONS

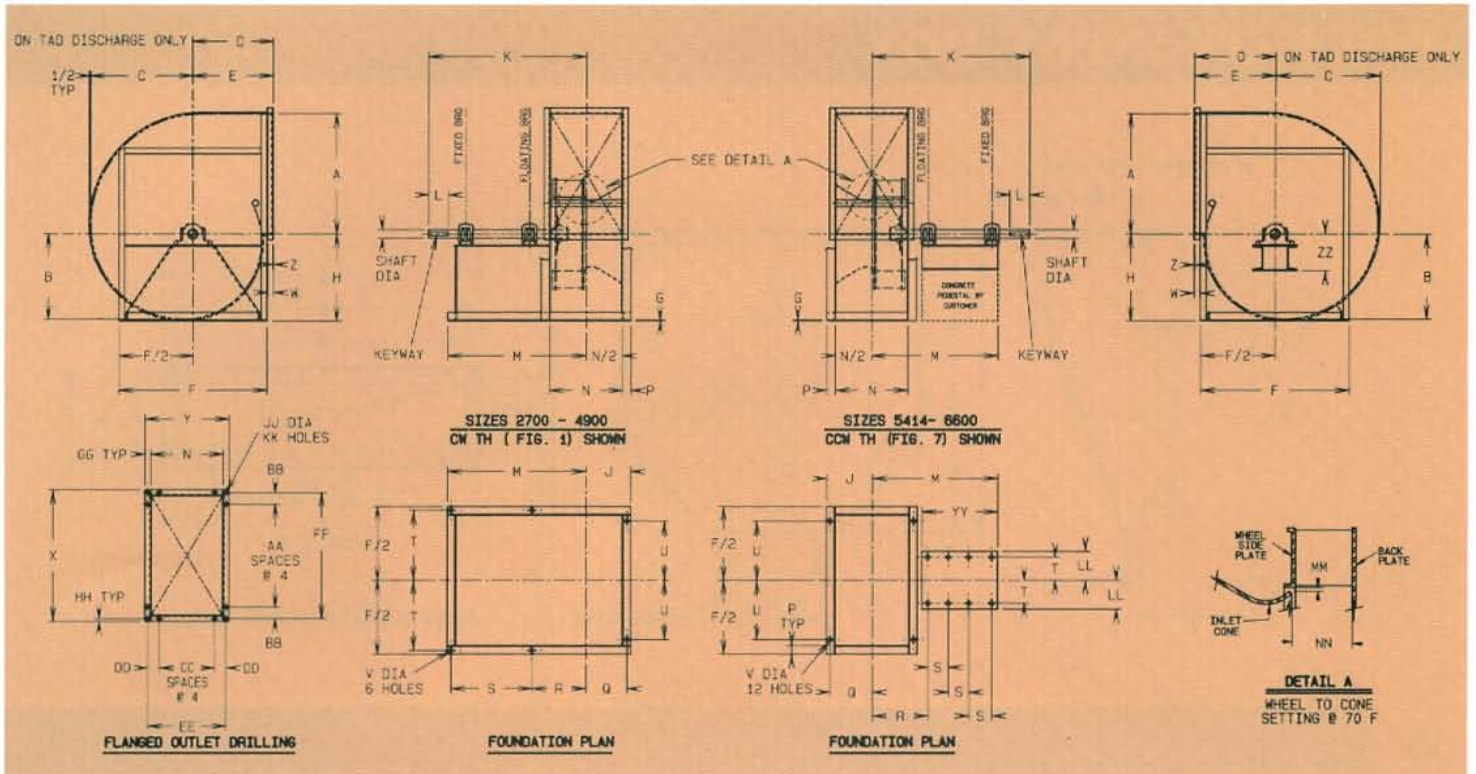

FAN SIZE	ASSEMBLY NO.	SHAFT DIA.	KEYWAY	A	B	C	D	E	F	G	H						J	K	L	M
											FIG. 1 & 7	FIG. 2 & 8	FIG. 3 & 9	FIG. 4 & 10	FIG. 5 & 11	FIG. 6 & 12				
2700	D19-1-452-1	27/16	5/8 x 5/16	30 11/16	21 23/32	26 3/16	33 1/2	22 5/8	40 3/4	1/4	22 1/4	34 3/4	27	29	26 3/4	24 1/2	11 3/4	44 15/16	7	38 3/4
3000	D19-1-452-2	2 1/16	5/8 x 5/16	34 7/8	24 7/8	29 1/8	36 1/2	24 3/8	44 1/2	1/4	24 3/4	38 1/8	29 1/4	32 1/8	29 3/4	27 1/4	12 3/4	49 7/16	8	42 1/4
3300	D19-1-452-3	2 15/16	3/4 x 3/8	37 7/16	26 9/16	32 1/16	39	26 1/8	47 3/4	1/4	27 1/8	41 1/2	31	35 3/8	32 5/8	29 7/8	13 7/8	51 1/4	8	44
3612	D19-1-452-4	2 15/16	3/4 x 3/8	41 1/2	29 9/16	35 3/8	41	27 3/4	51	3/8	29 7/8	45 1/2	32 3/8	38 15/16	35 15/16	32 7/8	15 1/2	54 3/8	8	47 5/8
4014	D19-1-452-5	3 7/16	7/8 x 7/16	45 3/4	32 3/8	39 1/16	44	30 3/4	55	3/8	32 7/8	49 3/4	34 1/2	43	39 3/4	36 1/4	16 7/8	57 1/2	8	51 1/8
4412	D19-1-452-6	3 7/16	7/8 x 7/16	50 5/8	35 13/16	43 3/32	52 3/4	33 3/8	60 1/2	3/8	37 1/8	55 5/8	41 3/4	48 7/16	44 11/16	41	18 5/8	58 7/8	8	52 9/16
4900	D19-1-452-7	3 11/16	1 x 7/16	55 3/4	39 7/16	47 5/8	56 13/16	36 7/16	66 1/4	3/8	40 7/8	60 3/4	44 3/8	53 1/8	49 1/16	45	19 13/16	65 7/8	10	56 11/16
5414	D19-1-454-1	3 15/16	1 x 1/2	61 11/16	43 3/8	52 3/8	61 1/4	40 9/16	72 1/2	3/8	45 1/8	66 11/16	46 3/16	58 11/16	54 1/8	49 9/8	21 1/16	71 1/2	11 1/2	58 5/16
6000	D19-1-454-2	4 15/16	1 1/4 x 5/8	68 1/4	48 1/4	58 1/4	68 3/16	44 1/2	79 1/2	3/8	49 3/4	74 1/4	52 1/2	64 3/4	59 3/4	54 3/4	24 5/8	86 1/16	11 1/2	68 11/16
6600	D19-1-454-3	4 15/16	1 1/4 x 5/8	75 1/16	53 1/16	64 1/16	71 3/8	48 15/16	84	3/8	54 9/16	81 1/16	56 5/8	71 1/16	65 9/16	60 1/16	26 11/16	90 3/4	11 1/2	72 9/16

FAN SIZE	N	P	Q	R	S	T	U	V	W	X	Y	Z	AA	BB	CC	DD	EE	FF	GG	HH	JJ
2700	18 1/2	2 1/2	10 5/8	14 1/4	23 3/8	19 1/4	15 1/2	5/8	2	34 11/16	22 1/2	1/4	6	4 1/32	3	4 3/8	20 3/4	32 15/16	2	7/8	1/2
3000	20 1/2	2 1/2	11 5/8	15 1/4	25 7/8	21 1/8	17 1/4	5/8	2	38 1/8	24 1/4	1/4	7	4 3/16	4	3 3/8	22 3/4	36 3/8	2	7/8	1/2
3300	22 3/4	2 1/2	12 3/4	16 3/8	26 1/2	22 3/4	18 7/8	5/8	2	41 9/16	26 3/4	1/4	8	3 29/32	5	2 1/2	25	39 13/16	2	7/8	1/2
3612	25	3	14 1/4	18 1/2	27 7/8	24 1/4	20 1/2	3/4	2	45 1/2	29	1/4	9	3 7/8	5	3 3/8	27 1/4	43 3/4	2	7/8	1/2
4014	27 3/4	3	15 5/8	19 7/8	30	26 1/4	21 1/2	3/4	2	49 3/4	31 3/4	1/4	10	4 3/32	6	3	30	48	2	7/8	1/2
4412	30 5/8	3	17 1/16	21 5/16	30	29	24 1/4	3/4	2	54 5/8	34 5/8	1/4	11	4 7/16	6	4 7/16	32 7/8	52 7/8	2	7/8	1/2
4900	33 3/16	3	18 15/16	22 13/16	32 13/16	31 7/8	27 3/8	3/4	2	59 1/4	37 9/16	1/4	13	3	7	3 29/32	35 13/16	58	2	7/8	1/2
5414	37 1/8	3	20 5/16	26 5/16	10	6 13/16	30 1/4	7/8	2	65 11/16	41 1/8	1/4	14	4	8	3 11/16	39 3/8	63 5/16	2	7/8	1/2
6000	41 1/4	4	23 1/8	29 5/8	12 3/8	8 5/16	33 3/4	7/8	3	74 1/4	47 1/4	1/4	16	3 7/8	9	4 3/8	44 3/4	71 1/4	3	1 1/4	3/4
6600	45 3/8	4	25 3/16	31 19/32	13	8 5/16	36	7/8	3	81 1/16	51 3/8	1/4	18	3 5/16	10	4 7/16	48 7/8	78 9/16	3	1 1/4	3/4

FAN SIZE	KK	LL	MM	NN	YY	ZZ	MAX. RPM AT 70°F	MIN. FAN SHEAVE PITCH DIA.	ROTOR WR2 LB - FT2	WEIGHT BARE FAN
2700	26	—	1 1/64	7 3/64	—	—	3340	4.9	57	800
3000	30	—	3/32	7 19/32	—	—	3072	5.4	113	1034
3300	34 3/4	—	7/64	8 5/16	—	—	2783	5.9	170	1469
3612	36	—	1/8	9 3/16	—	—	2361	6.2	251	1808
4014	40	—	1/8	10 3/16	—	—	2111	6.9	368	2434
4412	42	—	9/64	11 3/16	—	—	2009	6.9	705	3157
4900	48	—	5/32	12 21/64	—	—	1850	7.4	1028	3490
5414	52	8 13/16	1 1/64	13 11/64	34	16 5/16	1659	8.4	1527	4569
6000	58	10 5/16	9/32	14 7/8	41	17 5/8	1526	8.9	2342	7486
6600	64	10 5/16	2 1/64	16 9/32	43	17 5/8	1377	9.9	3449	9214

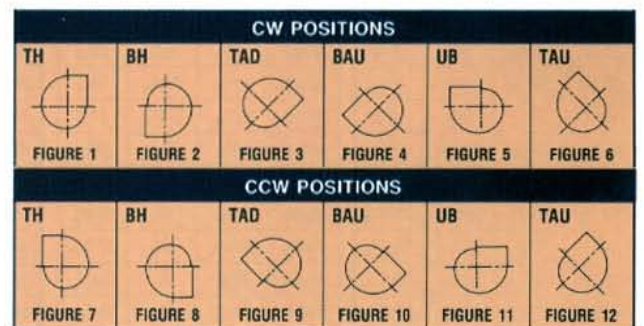

## BOLT-ON INLET BOX

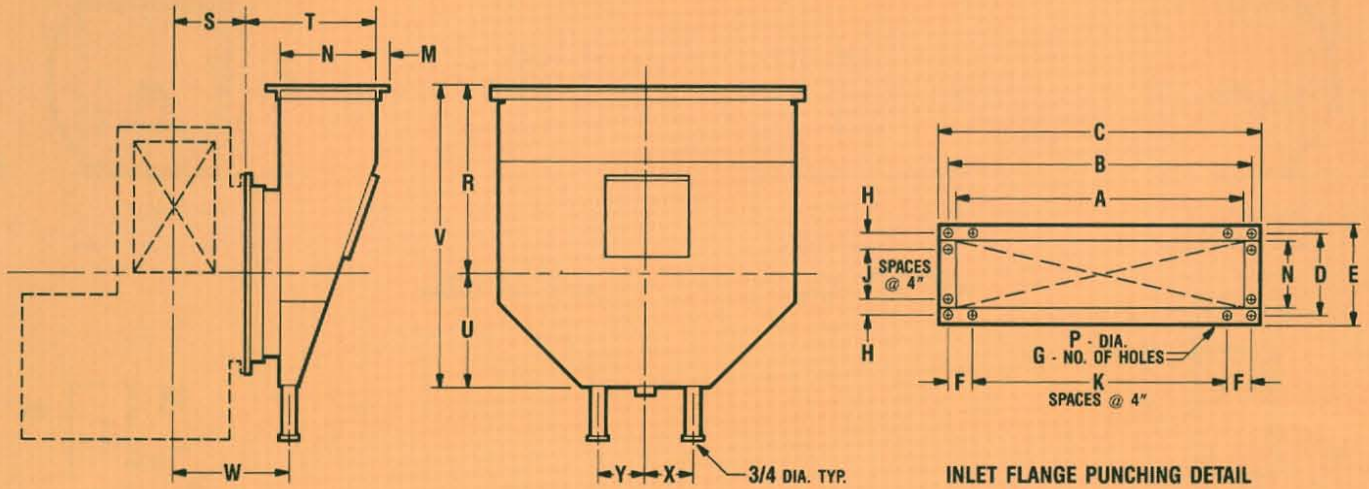

FAN SIZE	DIMENSIONS IN INCHES																WT. (lbs.)	
	A	B	C	D	E	F	G	H	J	K	N	P	R	S	T	U		V
2700	48½	50¾	52½	12⅝	14⅜	3⅜	32	4⅝	1	11	10⅜	½	30¼	13⅜	13	20½	50¾	256
3000	54	56¼	58	13⅝	15⅜	4⅛	34	4⅜	1	12	11⅜	½	32¾	14⅜	14¾	22¼	55	300
3300	59½	61¾	63½	14⅞	16⅝	2⅞	40	3⅞	2	14	12⅝	½	35¼	15½	16¾	24	59¼	447
3612	65¾	68	69¾	16⅜	17⅝	—	42	4⅜	2	17	13⅝	½	37½	18⅞	16⅜	25½	63	533
4014	73	75¼	77	17¾	19½	3⅝	46	4⅞	2	17	15½	½	40½	20	19⅞	27½	68	805
4412	80	82¼	84	19¼	21	3⅞	52	3⅞	3	19	17	½	44¼	21⅞	21⅞	30¼	74¼	956
4900	88¼	90½	92¼	21	22¾	3¼	56	4½	3	21	18¾	½	48¼	22⅞	24⅞	33¼	81½	1147
5414	98	100¼	102	23	24¾	4⅞	62	3½	4	23	20¾	½	52¾	24¾	28⅞	36¼	89	1373
6000	108	111½	114	26¼	28¾	3¼	70	3⅞	5	26	22¾	¾	53½	26⅞	31⅞	34¾	88¼	2260
6600	118½	122	124½	28⅞	31⅞	3	76	4⅝	5	29	25⅞	¾	56¾	28⅞	35⅞	36½	93¼	2523

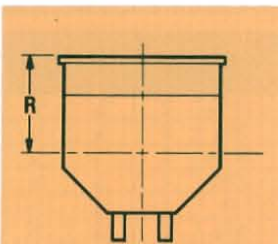

FIG 1 — POSITION 0°

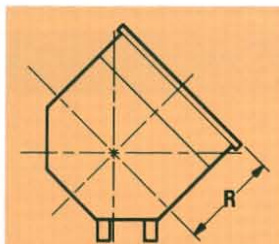

FIG 2 — POSITION 45°

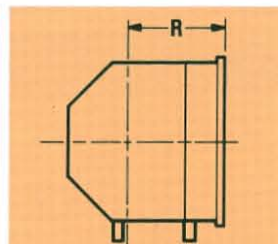

FIG 3 — POSITION 90°

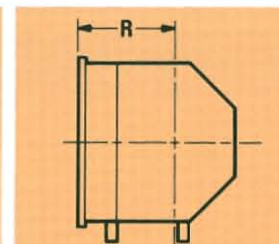

FIG 4 — POSITION 270°

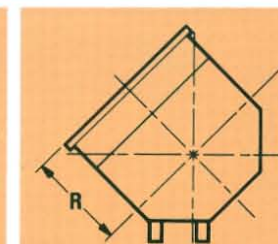

FIG 5 — POSITION 315°

FAN SIZE	W	X	Y
2700	16 <sup>29</sup> / <sub>32</sub>	9	9
3000	18 <sup>25</sup> / <sub>32</sub>	10⅞	10⅞
3300	20 <sup>29</sup> / <sub>32</sub>	11½	11½
3612	22 <sup>7</sup> / <sub>8</sub>	12¼	12¼
4014	25 <sup>9</sup> / <sub>16</sub>	13¾	13¾
4412	28 <sup>9</sup> / <sub>16</sub>	15⅜	15⅜
4900	30 <sup>29</sup> / <sub>32</sub>	16⅞	16⅞
5414	34 <sup>5</sup> / <sub>8</sub>	18⅞	18⅞
6000	38 <sup>7</sup> / <sub>16</sub>	20⅞	20⅞
6600	42 <sup>19</sup> / <sub>32</sub>	21⅞	21⅞

FAN SIZE	W	X	Y
2700	17	5⅞	11⅞
3000	19	5⅞	13½
3300	21⅞	5⅞	15¼
3612	23⅞	5⅞	17½
4014	25¾	6⅞	20⅞
4412	28½	7⅞	22⅞
4900	31 <sup>3</sup> / <sub>32</sub>	7¾	24⅞
5414	34 <sup>13</sup> / <sub>16</sub>	8½	27⅞
6000	38 <sup>5</sup> / <sub>8</sub>	6	34¼
6600	42 <sup>21</sup> / <sub>32</sub>	5¾	38⅞

FAN SIZE	W	X	Y
2700	19¾	5	22
3000	22⅞	5⅞	23⅞
3300	24⅞	5¼	25½
3612	27⅞	4⅞	26⅞
4014	30⅞	4¾	28⅞
4412	33⅞	5⅞	31⅞
4900	37 <sup>5</sup> / <sub>32</sub>	5⅞	34⅞
5414	41⅞	5⅞	37⅞
6000	46⅞	1⅞	36⅞
6600	51 <sup>25</sup> / <sub>32</sub>	¾	34⅞

FAN SIZE	W	X	Y
2700	19¾	22	5
3000	22⅞	23⅞	5⅞
3300	24⅞	25½	5¼
3612	27⅞	26⅞	4⅞
4014	30⅞	28⅞	4¾
4412	33⅞	31⅞	5⅞
4900	37 <sup>5</sup> / <sub>32</sub>	34⅞	5⅞
5414	41⅞	37⅞	5⅞
6000	46⅞	36⅞	1⅞
6600	51 <sup>25</sup> / <sub>32</sub>	34⅞	¾

FAN SIZE	W	X	Y
2700	17	11⅞	5⅞
3000	19	13½	5⅞
3300	21⅞	15¼	5⅞
3612	23⅞	17½	5⅞
4014	25¾	20⅞	6⅞
4412	28½	22⅞	7⅞
4900	31 <sup>3</sup> / <sub>32</sub>	24⅞	7¾
5414	34 <sup>13</sup> / <sub>16</sub>	27⅞	8½
6000	38 <sup>5</sup> / <sub>8</sub>	34¼	6
6600	42 <sup>21</sup> / <sub>32</sub>	38⅞	5¾

## RELATED CHICAGO AIRFOIL FAN LINES

### DESIGN 1900 SERIES

Variable diameter and width allows each fan to be sized for exact duty requirements. Design 1900 fans are available with integral welded inlet boxes, dependent or independent bearing pedestals, plus various materials and construction. Chicago builds fans to meet exact customer specifications.

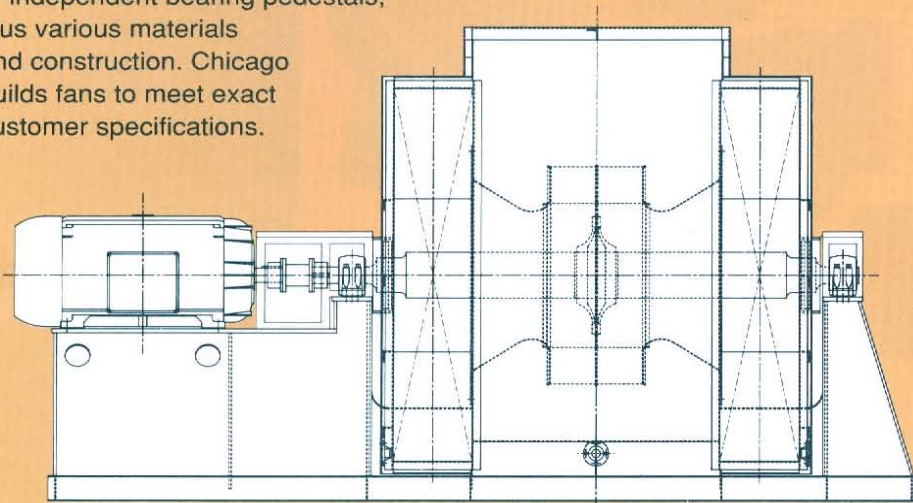

*Heavy duty airfoil fans are offered in many arrangements and constructions. Contact Chicago Blower or the nearest sales office for descriptive bulletins and further details.*

### PFD - PACKAGED FORCED DRAFT

A compact direct drive fan, the PFD is perfect for forced draft applications. Simple, sturdy and extremely efficient.

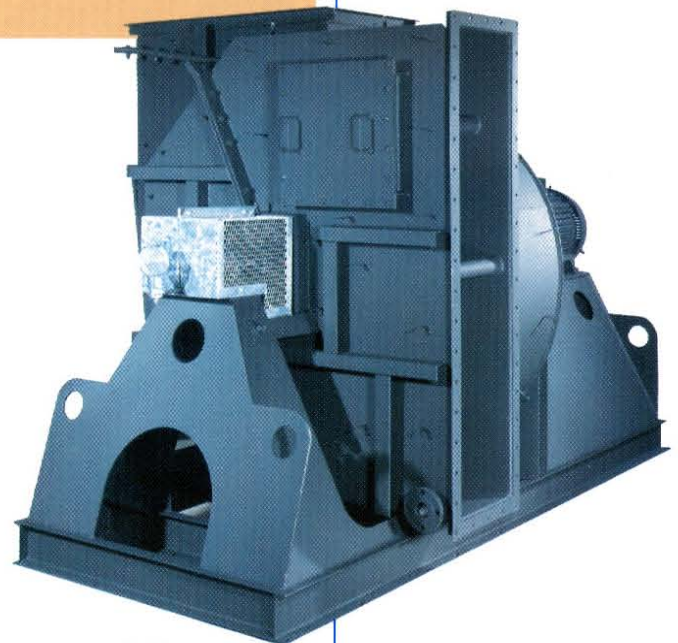

### API CONSTRUCTION

Chicago is one of a handful of manufacturers qualified in building fans for the petroleum and chemical industries. AWS certified code welding is done entirely in house.

*Setting the  
Standard  
For Quality*

**CHICAGO**

*Innovative Engineering  
Through Application Analysis*



*Quality Fans  
Shaped With  
Skill and Pride*



*Global Service Only a  
Click Away*

**Sales Offices  
Throughout  
North America**

*Chicago Blower Fans  
are also manufactured  
worldwide:*

Argentina, Australia, Brazil,  
Chile, China, Colombia,  
Denmark, Germany, Greece,  
Holland, Hong Kong, India,  
Indonesia, Israel, Italy,  
Japan, Korea, Malaysia,  
New Zealand, Norway,  
Philippines, Portugal,  
Saudi Arabia, Singapore,  
South Africa, Spain, Sweden,  
Thailand, Taiwan, Turkey,  
Venezuela.



***Your Primary Source For Every Fan Requirement***

**General Duty -**

*Airfoil and vane axial  
fans for clean exhaust  
or supply air*

**Industrial Duty -**

*Fans to handle  
dirty and corrosive  
environments*

**Heavy Duty -**

*Custom engineered  
fans for specific  
applications*

**CHICAGO BLOWER  
CORPORATION**

1675 Glen Ellyn Road, Glendale Heights, Illinois 60139

Phone: 630-858-2600 • Fax: 630-858-7172

www.chicagoblower.com e-mail: fans@chicagoblower.com